

JUPITER JM SERIES MEDIUM

Model : 160-180-200-220-240
Require HP : 40 to 60
Require KW : 29 to 45

Features / Características / Caractéristiques



Height Adjustable
Rear Roller

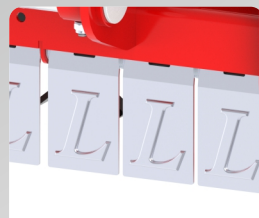

Advanced Protection Flap

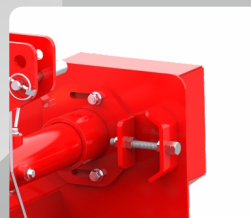

External Belt Tensioning
Quick and Simple



Easy Back Door Opening



Maximum back door opening

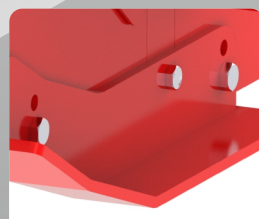

Adjustable Side Skids



Easy Greasing Points

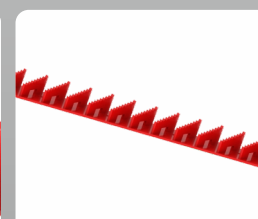

Counter Knives



Lancer Jupiter / Mulcher / Shredder / Flail Mower JM Series is ideal for intensive mulching of grass, shrubs, tree branches up to 6 CM in diameter. This series is designed for Vineyards, Orchards, Olive groves after pruning and Sugar cane residue . It can work with 40 to 60 HP Tractors .

Standard Equipment

- Electronically Balanced Rotor.
- Three Point Hitch Cat 2 Fixed
- Gearbox with Free Wheel 540 RPM
4 XPB Side Belt Transmission
- Rear Roller Adjustable in 3 Positions.
- Front Protection with Flaps
- Back Door Easy to Open & Close
(4 Adjustable Position Locking)
- Side Skids Adjustable in 2 Positions.
- Counter Knives.
- Advanced Tool Kit.

On Request

- Y-Blades or Hammers
- Rakes
- Rear Rubber Flaps
- CE PTO Guard



La serie Lancer Jupiter / Mulcher / Shredder / Flail Mower JM es ideal para el triturado intensivo de césped, arbustos y ramas de árboles de hasta 6 cm de diámetro. Esta serie está diseñada para Viñedos, Huertas, Olivares después de la poda y Residuos de Caña de Azúcar. Puede trabajar con Tractores de 40 a 60 HP.

Equipamiento estándar

- Rotor balanceado electrónicamente.
- Enganche de tres puntos Cat 2 Fijo
- Caja de Cambios con Rueda Libre 540 RPM
4 Transmisión de correa lateral XPB
- Rodillo Trasero Ajustable en 3 Posiciones.
- Protección Frontal con Solapas
- Puerta trasera fácil de abrir y cerrar
(bloqueo de 4 posiciones ajustables)
- Patines laterales regulables en
2 posiciones.
- Contracuchillos.
- Kit de herramientas avanzado.

Bajo pedido

- Hojas en Y o martillos
- rastrillos
- Aletas de goma traseras
- Protector de toma de fuerza CE



Lancer Jupiter / Broyeur / Broyeur / Tondeuse à fléaux JM Series est idéal pour le broyage intensif d'herbe, d'arbustes et de branches d'arbres jusqu'à 6 cm de diamètre. Cette série est conçue pour les vignobles, les vergers, les oliveraies après la taille et les résidus de canne à sucre. Il peut fonctionner avec des tracteurs de 40 à 60 CV.

Équipement standard

- Rotor équilibré électroniquement.
- Attelage trois points Cat 2 Fixe
Boîte de vitesses avec roue libre 540 RPM
- Transmission par courroie latérale 4 XPB
Rouleau arrière réglable en 3 positions.
- Protection avant avec rabats
- Porte arrière facile à ouvrir et à fermer
(verrouillage à 4 positions réglables)
- Patins latéraux réglables en 2 positions.
- Contre-couteaux.
- Kit d'outils avancés.

Sur demande

- Lames en Y ou marteaux
- Râteaux
- Rabats arrière en caoutchouc
- Garde de prise de force CE

Technical Details / Detalles técnicos / Détails techniques

Model No.	Working Width (MM)	Power Requirement		No of Blade	No of Hammer	Weight		Overall Dimension (MM)					
		KW	HP			Kg	LBS	mm	W inch	mm	D inch	mm	H inch
JM 160	1600	29 - 45	40 - 60	32 + 16	16	481	1060	1810	71	1130	44	990	39
JM 180	1800	29 - 45	40 - 60	40 + 20	20	515	1135	2010	79	1130	44	990	39
JM 200	2000	33 - 45	45 - 60	44 + 22	22	550	1212	2210	87	1130	44	990	39
JM 220	2200	37 - 45	50 - 60	48 + 24	24	585	1290	2410	95	1130	44	990	39
JM 240	2400	41 - 45	55 - 60	48 + 24	24	620	1367	2610	103	1130	44	990	39

*Machines weight mentioned without PTO Shaft

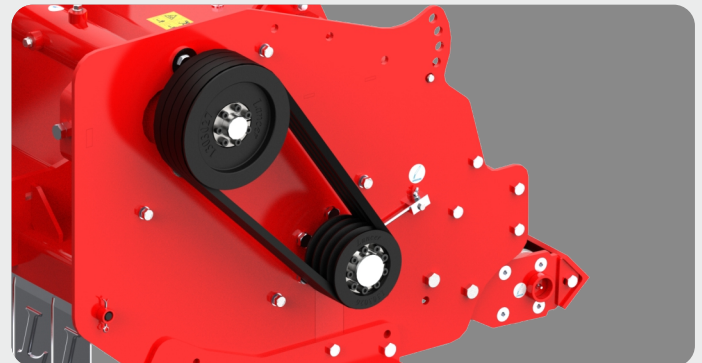
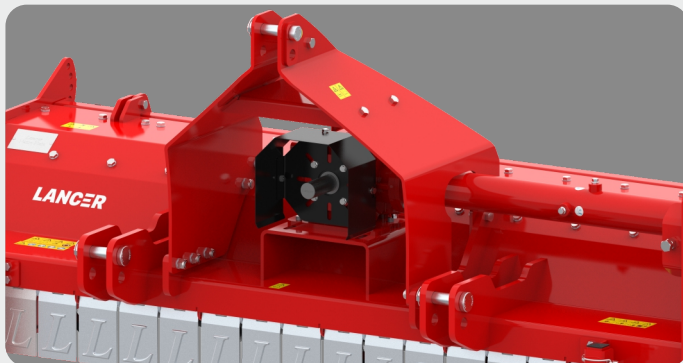

LANCER LASER TECH LTD.

Survey No-1434P/2, Chhatral-Mehsana Highway, Rajpur, Ta-Kadi, Dist. MehSana, Gujarat, India. 382715.

+912764-278801/02/03/04 sales@lanceragrico.com www.lanceragrico.com +91 88 99 33 55 33

Farmer's Friend



Scan and Get
Main Catalogue