

JUPITER JL SERIES LIGHT

Model : 100-120-140-160-180-200
Require HP : 18 to 55
Require KW : 13 to 41

Features / Características / Caractéristiques



Height Adjustable Rear Roller

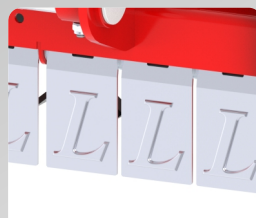

Advanced Protection Flap

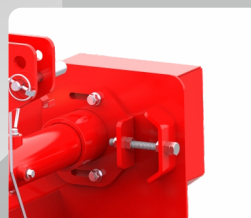

External Belt Tensioning
Quick and Simple



Easy back door opening



Maximum back door opening

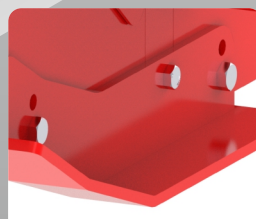

Adjustable Side Skids



Easy Greasing Points

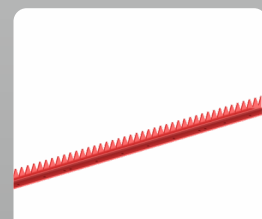

Counter Knives



Lancer Jupiter / Mulcher / Shredder / Flail Mower JL Series is ideal for shredding grass and shrubs up to 4 CM in diameter. This series is specially designed for working in Vineyards, Orchards and Paddy Field. It can work with 25 to 55 HP Tractors.

Standard Equipment

- Electronically balanced rotor
- 3 points linkage Cat. I & II.
- Gearbox with free wheel 540 RPM
- 3 XPB side belt transmission
- Front protection with flaps
- Back door easy to open & close (4 position locking with Plunger)
- Rear roller adjustable to 3 positions
- Side skids adjustable to 2 positions
- Counter knives screwed in 2 place
- Hammer Blades
- Advanced Tool Kit.

On Request

- Y-Blades or Hammers
- Rakes
- Rear Rubber Flaps
- CE PTO Guard



Lancer Jupiter / Mulcher / Shredder / Flail Mower serie JL es ideal para triturar hierba y arbustos de hasta 4 cm de diámetro. Esta serie está especialmente diseñada para trabajar en viñedos, huertas y arrozales. Puede trabajar con Tractores de 25 a 55 HP.

Equipamiento estándar

- Rotor balanceado electrónicamente.
- Enganche de tres puntos Cat 1-2 Fijo
- Caja de Cambios con Rueda Libre 540 RPM
- Desplazamiento lateral manual
- 3 Transmisión de correa lateral XPB
- Rodillo Trasero Ajustable en 3 Posiciones.
- Protección Frontal con Solapas
- Puerta trasera fácil de abrir y cerrar (bloqueo de 4 posiciones ajustables)
- Patines laterales regulables en 2 posiciones.
- Contracuchillos.
- Kit de herramientas avanzado.

Bajo pedido

- Hojas en Y o martillos
- rastrillos
- Aletas de goma traseras
- Protector de toma de fuerza CE



Lancer Jupiter / Broyeur / Broyeur / Tondeuse à fléaux JL Series est idéal pour broyer l'herbe et les arbustes jusqu'à 4 cm de diamètre. Cette série est spécialement conçue pour travailler dans les vignobles, les vergers et les rizières. Il peut fonctionner avec des tracteurs de 25 à 55 CV.

Équipement standard

- Rotor équilibré électroniquement.
- Attelage trois points Cat 1-2 Fixe
- Boîte de vitesses avec roue libre 540 RPM
- Déplacement latéral manuel
- Transmission par courroie latérale 3 XPB
- Rouleau arrière réglable en 3 positions.
- Protection avant avec rabats
- Porte arrière facile à ouvrir et à fermer (verrouillage à 4 positions réglables)
- Patins latéraux réglables en 2 positions.
- Contre-couteaux.
- Kit d'outils avancés.

Sur demande

- Lames en Y ou marteaux
- Râteaux
- Rabats arrière en caoutchouc
- Garde de prise de force CE

Technical Details / Detalles técnicos / Détails techniques

Model No.	Working Width (MM)	Power Requirement		No of Blade	No of Hammer	Weight		Overall Dimension (MM)					
		KW	HP			Kg	LBS	mm	W inch	mm	D inch	mm	H inch
JL 100	1000	13 - 41	18 - 55	24	12	272	600	1170	46	1000	39	880	34.5
JL 120	1200	18 - 41	25 - 55	32	16	302	666	1370	54	1000	39	880	34.5
JL 140	1400	22 - 41	30 - 55	36	18	331	730	1570	62	1000	39	880	34.5
JL 160	1600	26 - 41	35 - 55	40	20	360	794	1770	70	1000	39	880	34.5
JL 180	1800	29 - 41	40 - 55	44	22	394	869	1970	77	1000	39	880	34.5
JL 200	2000	33 - 41	45 - 55	48	24	425	937	2170	85	1000	39	880	34.5

*Machines weight mentioned without PTO Shaft

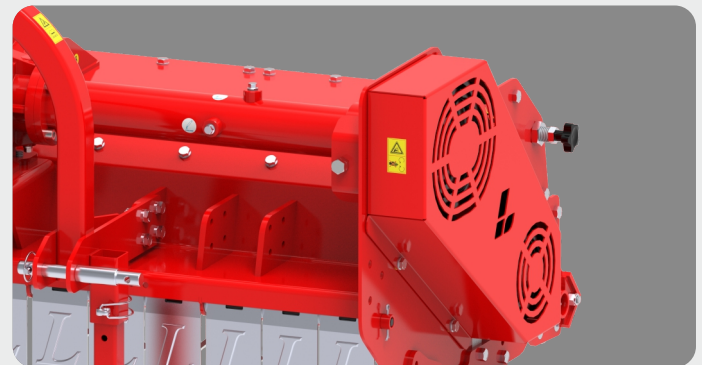
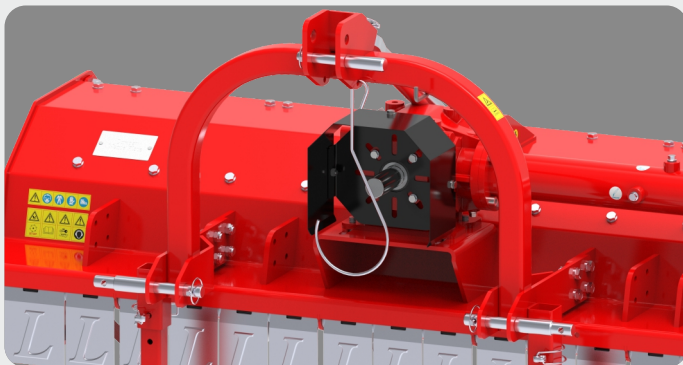

LANCER LASER TECH LTD.

Survey No-1434P/2, Chhatral-Mehsana Highway, Rajpur, Ta-Kadi, Dist. Mehana, Gujarat, India. 382715.

+912764-278801/02/03/04 sales@lanceragrico.com www.lanceragrico.com +91 88 99 33 55 33

Farmer's Friend



Scan and Get Main Catalogue